

MARINE HOOKS

Spring Towing Hook

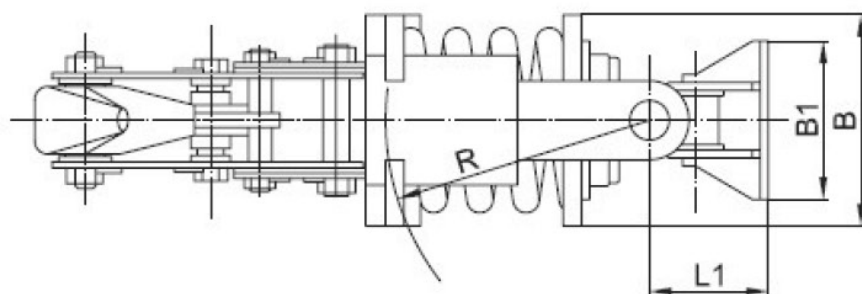

- The surface of part must be finishing. Can not have burr, shot mark, sharp corner, split and the other macroscopic irregularity.
- The forging parts must be normalizing treatment before doing machine work.
- All exteriority of part coat anticorrosive paint and all friction face of parts coat lube oil after acceptable test.
- The test weight is 2xSWL after tow hook with spring is finishing. The test time is not less than 5 minutes. All parts did not have permanent deformation, split and the other macula.

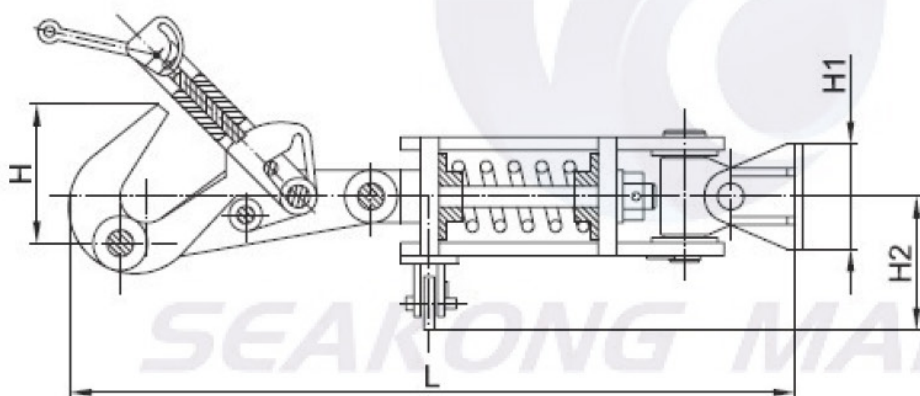

SWL(KN)	L	L1	B	B1	H	H1	H2	R	Weight(Kg)
16	822	145	232	150	180	150	157	309	56.6
25	916	142	260	130	190	130	141	345	83.7
40	1180	184	330	208	270	228	189.5	445	177.9
63	1411	196	342	200	284	160	192	563	267.9
100	1710	253	410	260	376	250	256.5	684	558.1
160	1936	270	458	320	400	210	261	741	646.9
220	2448	324	560	310	490	300	310	952	1269.1
320	2128	315	590	342	430	280	332	828	1058.8
400	2259	330	640	320	472	300	355	880	1340.1

Qingdao Seakong Marine Machinery Co.,Ltd

No. 19 Qutangxia Road, Shinan District, Qingdao City, China

Tel. +86 532 89922862 Fax. +86 532 89922862

Email: sales@seakongmarine.com Web: www.seakongmarine.com